

BTC



Dati tecnici ed immagini sono indicativi. Mickros si riserva di apportare aggiornamenti in qualsiasi momento e senza obbligo di preavviso.
Technical data and drawings are for information purposes only. Mickros reserves the right to update specs at anytime and without notice.

Mandrini Toolholders

CTO 4,5° Standard similar to DIN 69882-8

Mandrino per calettamento termico
Shrink fit chuck
Porte-outils de frettage
Schrumpfutter

p. 282

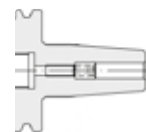

CTW 4,5° Standard Cooling Plus

Mandrino per calettamento termico con canali di lubrificazione
Shrink fit chuck with coolant bores
Porte-outils de frettage avec conduits d'arrosage
Schrumpfutter mit Kühlmittelbohrung

p. 284

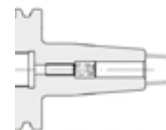

CTP 4,5° without back up screw

Mandrino per calettamento termico estensibile, adatto per prolunghe
Extensible shrink fit-chuck suitable for extensions
Porte outils de frettage prolongeable approprié pour rallonges
Verlängerbares schrumpfutter geeignet für verlängerungs

p. 286

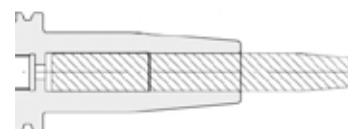

CTF 3° Slim without back up screw

Mandrino per calettamento termico. Ideale per la costruzione di STAMPI e cavità profonda
Shrink fit chuck. Suitable for the MOLD and for deep cavities
Porte outils de frettage. Idéal pour la construction de MOLD et des cavités profondes
Schrumpfutter für tiefe Kavitäten geeignet, speziell für den Gesenk, und Formenbau

p. 288

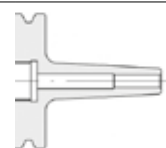

ERM - Mini DIN 6499

Portapinze di precisione ER - Mini DIN 6499
Precision collet chuck ER - Mini DIN 6499
Porte pinces de precision ER - Mini DIN 6499
Präzisions spannzangenfutter ER - Mini DIN 6499

p. 290

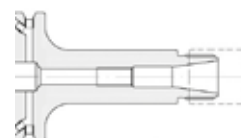

ERH High Performance

Portapinze di precisione ER DIN 6499
Precision collet chuck ER DIN 6499
Porte pinces de precision ER DIN 6499
Präzisions spannzangenfutter ER DIN 6499

p. 292

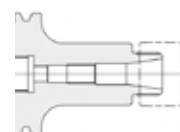

PUH Din 6595-Din 6535 HE

Mandrino portapunte
Adapter for drilling tools
Porte-foret
Aufnahme für Vollbohrer

p. 294

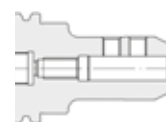

WEC Weldon DIN 1835-8

Portafrese Weldon corto
End-mill holder Weldon type short execution
Mandrin porte-fraise Weldon type court
Weldon-kegelaufnahme Kurze Ausführung

p. 296



WEW Cooling Plus DIN 6535-HB / 6535-HE

Mandrini per attacchi Weldon – WN con canali di lubrificazione
Weldon – WN toolholders with coolant bores
Porte outils Weldon – WN avec conduits d'arrosage
Weldon-WN aufnahme mit Kühlmittelbohrung

p. 298



MDH

Portafrese con filetto interno, per frese con attacco filettato
Cutter-Holder with modular threaded connection
Mandrin Porte-Fraise avec attachement modulaire fileté
Fraseraufnahme mit modular-gewinde aufnahme

p. 300

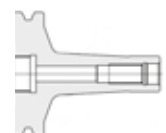

FSW Cooling Plus DIN 6357 B

Portafrese a spianare con trascinatore fisso - con canali di lubrificazione
Face mill arbor with coolant bores
Porte-fraises à surfaçer avec conduits d'arrosage
Messerkopf- aufnahme mit Kühlmittelbohrung

p. 302

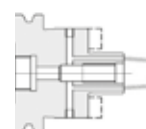

Codoli per BT

Spina di controllo
Control pin
Barre de contrôle
Prüfdorn

p. 304



Termokurczliwe Uchwyty Narzędziowe Maszyny
SIMILAR
ISO 7388-2 (MAS 403BT) - JD form

FACE CONTACT

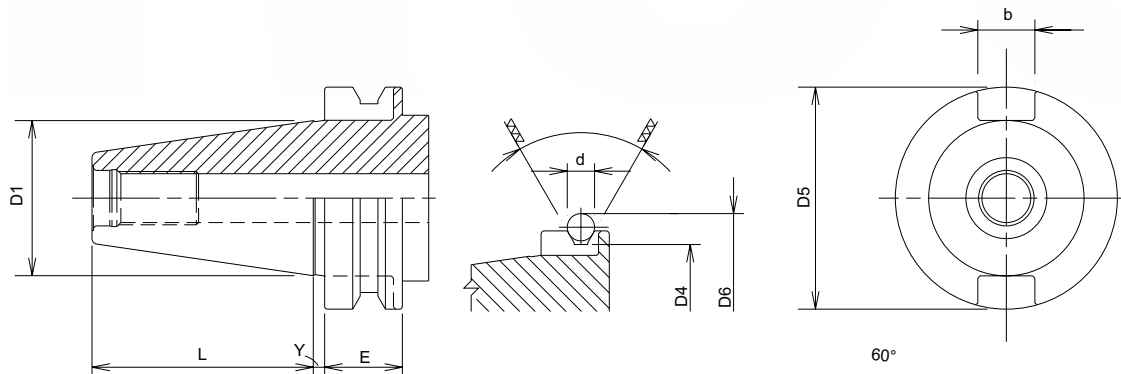

	030	040	050
b	16,1	16,1	25,7
d	8	10	15
E	21	26	36,5
D1	31,75	44,45	69,85
D4	38	53	85
D5	46	63	100
D6	56,144	75,679	119,020
L	48,40	65,40	101,80
Y	1	1	1,5

Mandrini a fissaggio meccanico

- Temprati e cementati con durezza 60 - 2 HRC
- Resistenza alla trazione 950 N/mm²
- Attacco con qualità tolleranza cono AT3

Mandrini per il calettamento a caldo

- Acciaio speciale per lavorazioni a caldo resistente alle alte temperature
- Temprato 54 - 2 HRC

Note

Forma JD:

- alimentazione interna del lubrorefrigerante attraverso foro centrale

Tool holders:

- Case-hardened 60 - 2 HRC
- Tensile strength in the core at least 950 N/mm²
- Taper in tolerance quality AT3

Shrink fit chuck:

- Heat resistant hot-working steel
- Hardened 54 - 2 HRC

Note

Forma JD:

- central coolant supply

CTO 4,5° standard (similar to DIN 69882-8)

Mandrino per calettamento termico

Shrink fit chuck

Porte-outils de frettage

Schrumpfutter



MANDRINI A CALETTAMENTO

simile a DIN 69882-8

- Chuck Body Fine Balanced
- G 2,5 - 25.000 Rpm - Or U < 1 gmm
- Run Out 3 micron
- Angolo di calettamento esterno 4,5° gradi
- Con grano di registrazione assiale
- Ø 3-4-5 senza grano di registrazione assiale
- Per utensili in HSS e in HM
- Tolleranza gambo utensile "h6"
- Raffreddamento con fori di refrigerazione "A RICHIESTA"

- Con fori di refrigerazione VEDI "CTW"
- Fori di refrigerazione "A RICHIESTA"

SHRINK FIT CHUCKS

similar to DIN 69882-8

- Chuck Body Fine Balanced
- G 2,5 - 25.000 Rpm - Or U < 1 gmm
- Run Out 3 micron
- 4,5° slope at the top
- With back-up screw
- Ø 3-4-5 Without back-up screw
- For carbide steel and HSS shanks
- For tools with shank tolerance h6
- With coolant channels ON REQUEST

- With coolant channels SEARCH "CTW"
- Coolant Channels "ON REQUEST"

Accessori | Accessories

PST



p. 304

ASC



p. 310

Ricambi | Spare parts

RVR CTW



p. 352

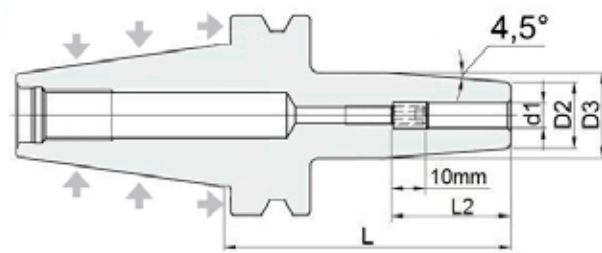

BTC 040 (JD form) - CTO 4,5 STANDARD

codice - code	d1	L	D2	D3	L2	g	L5 minimum grip	Fori Refrigerazione Coolant Channels	APPLICATION
BTC.040.CT003.090	3	90	9	20		No RVR	9	--	
BTC.040.CT004.090	4	90	10	20		No RVR	12	--	
BTC.040.CT005.090	5	90	11	20		No RVR	15	--	
BTC.040.CT006.090	6	90	21	27	37	M5 x 0,8	22	•	
BTC.040.CT006.130	6	130	21	27	37	M5 x 0,8	22	•	
BTC.040.CT006.160	6	160	21	27	37	M5 x 0,8	22	•	
BTC.040.CT008.090	8	90	21	27	37	M6 x 1	26	•	
BTC.040.CT008.130	8	130	21	27	37	M6 x 1	26	•	
BTC.040.CT008.160	8	160	21	27	37	M6 x 1	26	•	
BTC.040.CT010.090	10	90	24	32	42	M8 x 1	31	•	
BTC.040.CT010.130	10	130	24	32	42	M8 x 1	31	•	
BTC.040.CT010.160	10	160	24	32	42	M8 x 1	31	•	
BTC.040.CT012.090	12	90	24	32	47	M10 x 1	36	•	
BTC.040.CT012.130	12	130	24	32	47	M10 x 1	36	•	
BTC.040.CT012.160	12	160	24	32	47	M10 x 1	36	•	
BTC.040.CT014.090	14	90	27	34	47	M10 x 1	36	•	
BTC.040.CT014.130	14	130	27	34	47	M10 x 1	36	•	
BTC.040.CT016.090	16	90	27	34	50	M12 x 1	39	•	
BTC.040.CT016.130	16	130	27	34	50	M12 x 1	39	•	
BTC.040.CT016.160	16	160	27	34	50	M12 x 1	39	•	
BTC.040.CT018.090	18	90	33	41	50	M12 x 1	39	•	
BTC.040.CT018.130	18	130	33	41	50	M12 x 1	39	•	
BTC.040.CT020.090	20	90	33	41	52	M16 x 1	41	•	
BTC.040.CT020.130	20	130	33	41	52	M16 x 1	41	•	
BTC.040.CT020.160	20	160	33	41	52	M16 x 1	41	•	
BTC.040.CT025.100	25	100	44	53	58	M16 x 1	47	•	
BTC.040.CT025.160	25	160	44	53	58	M16 x 1	47	•	
BTC.040.CT032.100	32	100			62	M16 x 1	51	•	

CTW Cooling Plus

Mandrino per calettamento termico con canali di lubrificazione

Shrink fit chuck with coolant bores

Porte-outils de frettage avec conduits d'arrosage

Schrumpfutter mit Kühlmittelbohrung

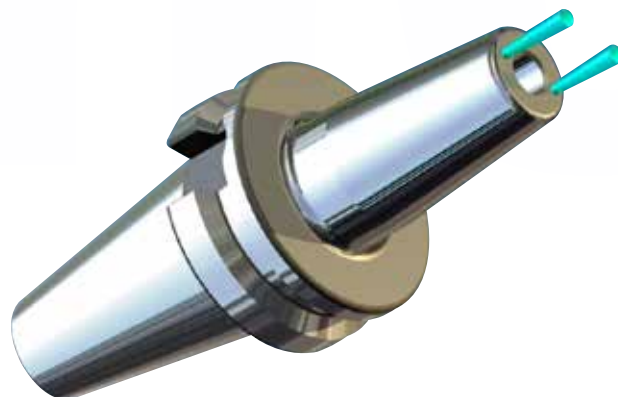

MANDRINI A CALETTAMENTO Cooling Plus

- Chuck Body Fine Balanced
G 2,5 - 25.000 Rpm - Or U < 1 gmm
- Run Out 3 micron
- Angolo di calettamento esterno 4,5° gradi
- Con grano di registrazione assiale
- Per utensili in HSS e in HM
- Tolleranza gambo utensile "h6"
- Fori di refrigerazione "STANDARD" richiudibili

SHRINK FIT CHUCKS Cooling Plus

- Chuck Body Fine Balanced
G 2,5 - 25.000 Rpm - Or U < 1 gmm
- Run Out 3 micron
- 4,5° slope at the top
- With back-up screw
- For carbide steel and HSS shanks
- For tools with shank tolerance h6
- With coolant channels

Accessori | Accessories

PST



p. 304

ASC



p. 310

Ricambi | Spare parts

RVR CTW



p. 352

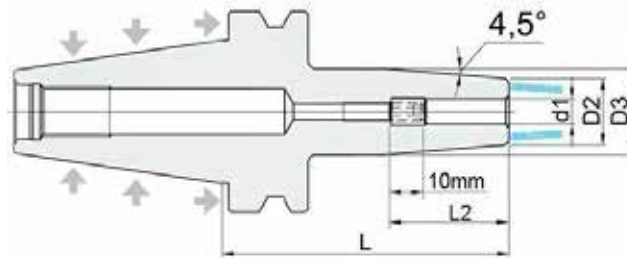

BTC 040 (JD form) - CTW Cooling Plus

codice - code	d1	L	D2	D3	L2	G	L5 minimum grip	APPLICATION
BTC.040.CTW06.090	6	90	21	27	37	M5 x 0,8	22	
BTC.040.CTW06.130	6	130	21	27	37	M5 x 0,8	22	
BTC.040.CTW08.090	8	90	21	27	37	M6 x 1	26	
BTC.040.CTW08.130	8	130	21	27	37	M6 x 1	26	
BTC.040.CTW10.090	10	90	24	32	42	M8 x 1	31	
BTC.040.CTW10.130	10	130	24	32	42	M8 x 1	31	
BTC.040.CTW12.090	12	90	24	32	47	M10 x 1	36	
BTC.040.CTW12.130	12	130	24	32	47	M10 x 1	36	
BTC.040.CTW14.090	14	90	27	34	50	M12 x 1	36	
BTC.040.CTW14.130	14	130	27	34	50	M12 x 1	36	
BTC.040.CTW16.090	16	90	27	34	50	M12 x 1	39	
BTC.040.CTW16.130	16	130	27	34	50	M12 x 1	39	
BTC.040.CTW20.090	20	90	33	41	52	M16 x 1	41	
BTC.040.CTW20.130	20	130	33	41	52	M16 X 1	41	
BTC.040.CTW25.100	25	100	44	53	58	M16 x 1	47	

CTP 4,5°

Mandrino per calettamento termico estensibile, adatto per prolunghe

Extensible shrink fit-chuck suitable for extensions

Porte outils de frettage prolongeable approprié pour rallonges

Verlängerbares schrumpfutter geeignet für verlängerungs



MANDRINI A CALETTAMENTO per prolunghe e riduzioni prolungate

Consigliato per uso di prolunghe e riduzioni prolungate

- Chuck Body Fine Balanced
- G 2,5 - 25.000 Rpm - Or U < 1 gmm
- Run Out 3 micron
- Angolo di calettamento esterno 4,5° gradi
- (*) Estensibile - impostazione di lunghezza variabile
- Senza grano di registrazione assiale
- Raffreddamento con fori di refrigerazione "A RICHIESTA"
- Per utensili in HSS e in HM
- Tolleranza gambo utensile "h6"

SHRINK FIT CHUCKS for extensions

Suitable to use with extensions and reduction

- *Chuck Body Fine Balanced*
- *G 2,5 - 25.000 Rpm - Or U < 1 gmm*
- *Run Out 3 micron*
- *4,5° slope at the top*
- *(*) Extensible - Variable length setting*
- *Without back-up screw*
- *With coolant channels ON REQUEST*
- *For carbide steel and HSS shanks*
- *For tools with shank tolerance h6*

Accessori | Accessories



p. 304



p. 310



p. 31

Ricambi | Spare parts

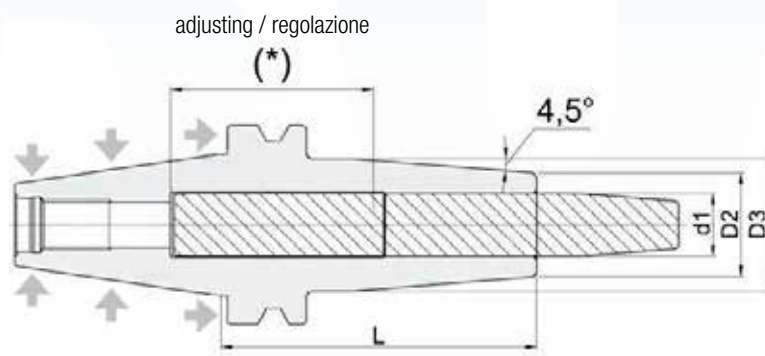

BTC 040 (JD form) - CTP 4,5°

codice - code	D1	L	D2	D3	(*)	Minimum Grip	APPLICATION
BTC.040.CTP16.090	16	90	27	34	(*) 67	39	
BTC.040.CTP20.090	20	90	33	41	(*) 65	41	
BTC.040.CTP25.100	25	100	44	53	(*) 49	47	

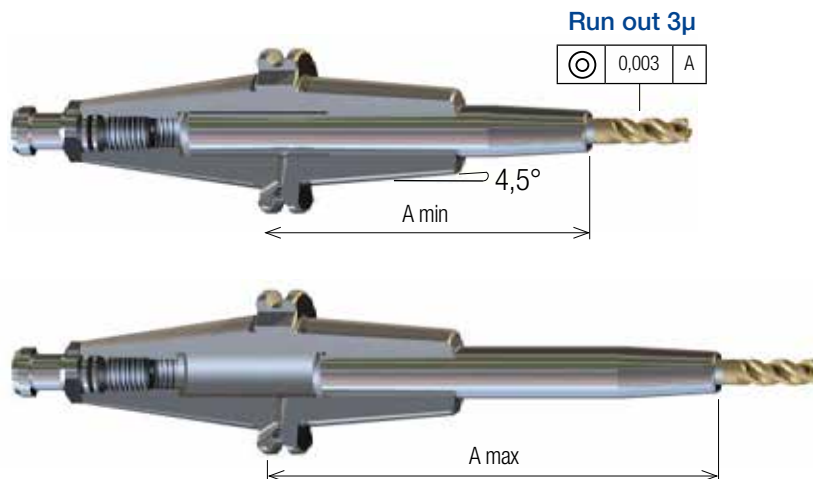

CTF slim - 3°

Mandrino per calettamento termico. Ideale per la costruzione di STAMPI e cavità profonde

Shrink fit chuck. Suitable for the MOLD and for deep cavities

Porte outils de frettage. Idéal pour la construction de MOLD et des cavités profondes

Schrumpfutter für tiefe Kavitäten geeignet, speziell für den Gesenk, und Formenbau

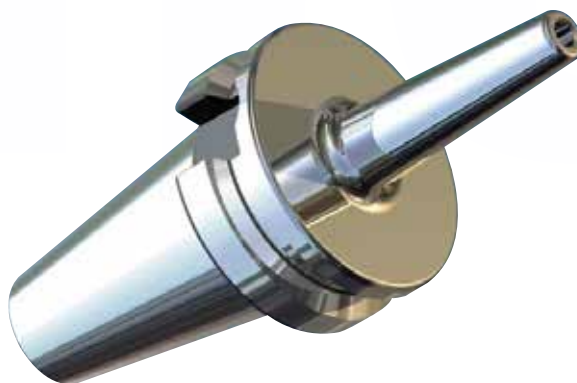

MANDRINI A CALETTAMENTO

Slim - 3°

MANDRINO A CALETTAMENTO DI FINITURA

- Chuck Body Fine Balanced
G 2,5 - 25.000 Rpm - Or U < 1 gmm
- Run Out 3 micron
- Angolo esterno inclinazione di 3° PER STAMPI
- Spessore Parete 3mm
- Senza grano di registrazione assiale
- Solo per utensili in HM
- Tolleranza gambo utensile "h6"

SHRINK FIT CHUCKS

Slim - 3°

SHRINK FIT CHUCK FOR FINISHING

- Chuck Body Fine Balanced
G 2,5 - 25.000 Rpm - Or U < 1 gmm
- Run Out 3 micron
- 3° slope at the top .Suitable for the MOLD
- 3 mm. wall thickness
- Without back-up screw
- Only for carbide tools
- For tools with shank tolerance h6

Accessori | Accessories

PST



p. 304

ASC



p. 310

Ricambi | Spare parts

spessore parete 3 mm - 3 mm wall thickness

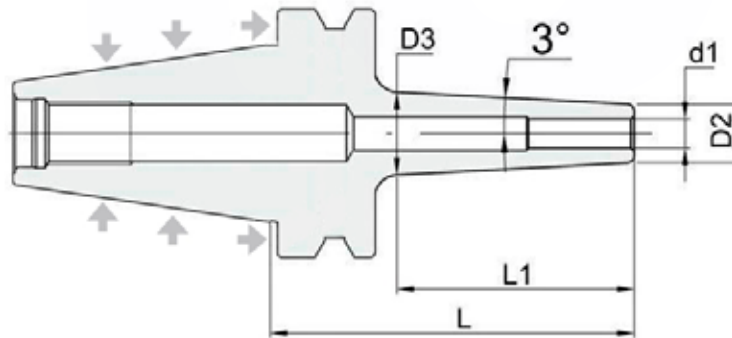

BTC 040 (JD form) - CTF slim - 3°

codice - code	D1	L	D2	D3	L1	APPLICATION
BTC.040.CTF03.090-30	3	90	9	15	58	
BTC.040.CTF03.130-30	3	130	9	19	95	
BTC.040.CTF04.090-30	4	90	10	16	58	
BTC.040.CTF04.130-30	4	130	10	20	95	
BTC.040.CTF06.090-30	6	90	12	18	58	
BTC.040.CTF06.130-30	6	130	12	22	95	
BTC.040.CTF08.090-30	8	90	14	20	58	
BTC.040.CTF08.130-30	8	130	14	24	95	
BTC.040.CTF10.090-30	10	90	16	22	58	
BTC.040.CTF10.130-30	10	130	16	26	95	
BTC.040.CTF12.090-30	12	90	18	24	58	
BTC.040.CTF12.130-30	12	130	18	28	95	

ERM - Mini DIN 6499

Portapinze di precisione ER - Mini DIN 6499

Precision collet chuck ER - Mini DIN 6499

Porte pincés de précision ER - Mini DIN 6499

Prazisions spannzangenfutter ER - Mini DIN 6499



PORTAPINZE ERM - Mini type High Performance

- Chuck Body Fine Balanced
G 2,5 - 25.000 Rpm - Or U < 1 gmm
- Run Out 3 micron
- Con grano di registrazione assiale
- Ghiera RGM tipo Mini

COLLET CHUCKS ERM - Mini type High Performance

- Chuck Body Fine Balanced
G 2,5 - 25.000 Rpm - Or U < 1 gmm
- Run Out 3 micron
- With back-up screw
- Mini type nuts RGM

Accessori | Accessories

PST



p. 304

PER Q



p. 322

ACH GM



p. 344

ASC



p. 310

Ricambi | Spare parts

RGM



p. 338

RVR ER



p. 352

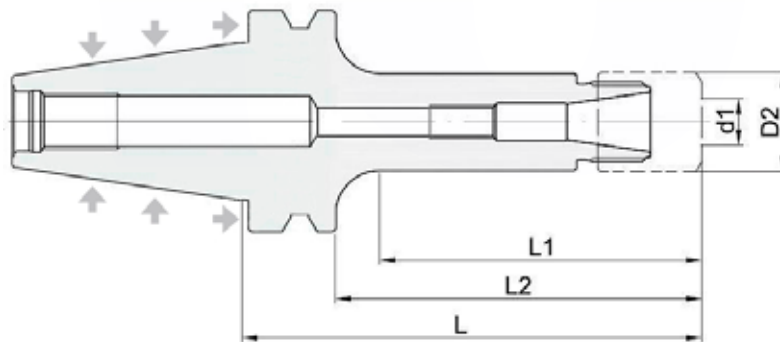

BTC 040 (JD form) - ERM - Mini

CODICE-CODE	d1	L	D2	L2	L1	Nuts/ghiere	APPLICATION
BTC.040.ERM11.100-G25	0,5-7	100	16	73	63	RGM-Mini	
BTC.040.ERM16.100-G25	1-10	100	22	73	63	RGM-Mini	
BTC.040.ERM20.100-G25	1-13	100	28	73	63	RGM-Mini	

ERH DIN 6499

Portapinze di precisione ER DIN 6499

Precision collet chuck ER DIN 6499

Porte pinces de precision ER DIN 6499

Prazisions spannzangenfutter ER DIN 6499



PORTAPINZE - ER type H/P High Performance

- Chuck Body Fine Balanced
G 2,5 - 25.000 Rpm - Or U < 1 gmm
- Run Out 3 micron
- Con grano di registrazione assiale

COLLET CHUCKS ER type H/P High Performance

- Chuck Body Fine Balanced
G 2,5 - 25.000 Rpm - Or U < 1 gmm
- Run Out 3 micron
- With back-up screw

Accessori | Accessories

PST



p. 304

PER Q



p. 322

ACH GS



p. 344

ACH GX



p. 344

ASC



p. 310

Ricambi | Spare parts

RGX



p. 339

RGE



p. 341

RVR ER



p. 352

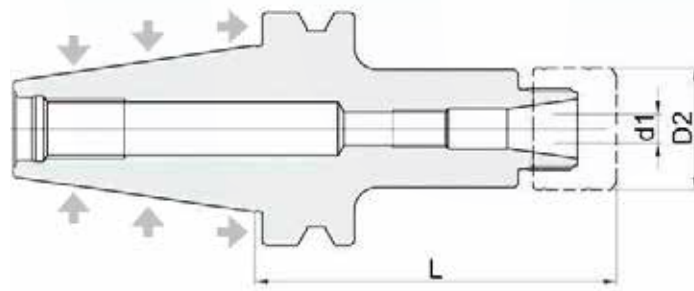

BTC 040 (JD form) - ERH

codice - code	d1	L	D2	Nuts/ghiere	on-request Nuts/ghiere	APPLICATION
BTC.040.ERH16.070	0,5-10	70	32	RGE	RGX.ER16 D 2=28	
BTC.040.ERH16.100	0,5-10	100	32	RGE	RGX.ER16 D 2=28	
BTC.040.ERH16.130	0,5-10	130	32	RGE	RGX.ER16 D 2=28	
BTC.040.ERH16.160	0,5-10	160	32	RGE	RGX.ER16 D 2=28	
BTC.040.ERH25.070	1,5-16	70	42	RGE		
BTC.040.ERH25.100	1,5-16	100	42	RGE		
BTC.040.ERH25.130	1,5-16	130	42	RGE		
BTC.040.ERH25.160	1,5-16	160	42	RGE		
BTC.040.ERH32.070	2,5-20	70	50	RGE		
BTC.040.ERH32.100	2,5-20	100	50	RGE		
BTC.040.ERH32.130	2,5-20	130	50	RGE		
BTC.040.ERH32.160	2,5-20	160	50	RGE		

PUH DIN 6595 / 6535 HE

Mandrino portapunte

Adapter for drilling tools

Porte-foret

Aufnahme für Vollbohrer



MANDRINO PORTAPUNTE

- Run Out 3 micron
- Grano di registrazione assiale
- Minore ingombro come illustrato in tabella D2
- Maggiore precisione di coassialità ($d1 +0/+0,005$)
- Minore peso e maggiore bilanciabilità
- Maggiore resistenza alla torsione grazie alla posizione disassata dei grani di serraggio utensile
- Possibilità di utilizzo di punte ad inserto gambo diam. 40
- Maggiore rigidità con utensili con battuta

OPTIONAL:

Possibilità di usare grano con semisfera basculante AVS HWN10 per diam. 14 ÷ 25
per attacchi Whistle Notch Din 1835 E - Din 6535 HE

ADAPTER FOR DRILLING TOOLS

- Run Out 3 micron
- With set-up screw
- Fewer obstacles as shown in table D2
- Greater axial precision ($d1 +0/+0,005$)
- Less weight and better balance
- Greater resistance to torsion thanks to offset position of tool tightening screws
- Possible to use insertion tips with tool shank diameter 40
- Greater rigidity above all tools with abutting end

OPTIONAL:

Possibility to use screw with horizontally pivoted halfsphere AVS HWN10 for diam. 14 ÷ 25
For Whistle Notch type Din 1835 E-Din 6535 HE

Accessori | Accessories

PST



p. 304

ABR



p. 349

AVS



p. 351

ASC



p. 310

Ricambi | Spare parts

RVU 5923



p. 353

RVR WN



p. 353

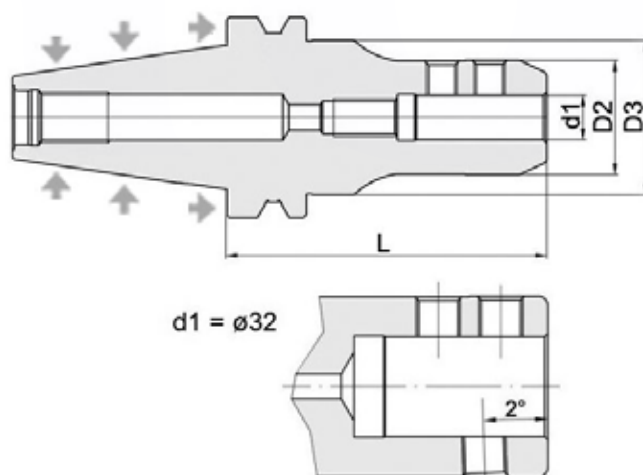

BTC 040 (JD form) - PUH

codice - code	d1 - H5	L	D2	D3		APPLICATION
BTC.040.PUH20.100	20	100	42	50		DIN 6595DIN 6535 HE
BTC.040.PUH25.100	25	100	48			DIN 6595DIN 6535 HE
BTC.040.PUH32.080	32	80	58		No RVR	DIN 6595DIN 6535 HE
BTC.040.PUH40.080	40	80	63		No RVR	DIN 6595

WEC Weldon DIN 1835-B

Portafrese Weldon corto

End-mill holder Weldon type short execution

Mandrin porte-fraise Weldon type court

Weldon-kegelaufnahme Kurze Ausführung



MANDRINI EXTRA CORTI per attacchi Weldon

- Run Out 3 micron
- Particolarmente adatti per volumi di truciolatura elevati
- Consigliati nella formazione della Forma "KOMBI" con maschiatori cilindrici CWE...
- Ottimo abbinamento con Prolunghe Rinforzate MDW (con attacco Weldon) per frese con attacco filettato

TOOL HOLDERS Weldon Extra Short

- Run Out 3 micron
- High Performance Cutting
- Suitable to use in "KOMBI" form, with cylindrical tapping chuck CWE...
- Optimal combination with strengthened extensions MDW (Weldon shank) for threaded type cutter

Accessori | Accessories

PST



p. 304

ASC



p. 310

Ricambi | Spare parts

RVD 1835



p. 353

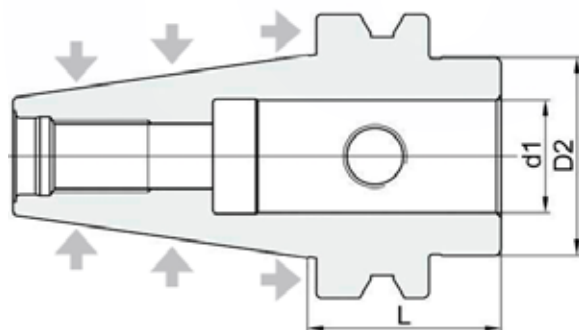

BTC 040 (JD form) - WEC Weldon

codice - code	d1	L	D2					APPLICATION
BTC.040.WEC20.035	20	35	35					
BTC.040.WEC25.035	25	35	50					
BTC.040.WEC32.075	32	75	72					

WEW Cooling Plus DIN 6535 HB / 6535 HE

Mandrini per attacchi Weldon - WN (WEW con canali di lubrificazione)

Weldon - WN toolholders (WEW with coolant bores)

Porte outils Weldon - WN (WEW avec conduits d'arrosage)

Weldon - WN (WEW aufnahme mit kühlmittellbohrung)



MANDRINI per attacchi Weldon-Whistle Notch WEW - Cooling Plus

- Run Out 3 micron
- Fori di refrigerazione "STANDARD" richiudibili

Tutti i mandrini WEH - WEW Mickros Plus dal diam. 6 al diam. 12 possono montare:

- frese con gambo Weldon (DIN 1835-B)
- punte con gambo Whistle Notch (DIN 1835-E)

OPTIONAL:

Cod. AVK WN (\emptyset d1 = 6 - 12)

Whistle Notch Din 1835 E-Din 6535 HE

- Vite speciale con sfera oscillante per il serraggio di utensili con piano inclinato 2° "AVSH WN..."
- Grano per la regolazione assiale dell'utensile "RVR..."

TOOL HOLDERS Weldon-Whistle Notch WEW - Cooling Plus

- Run Out 3 micron
- With coolant channels "Standard"

All of the spindles WEH - WEW Mickros Plus diameter from 6 to 12 can mount:

- both cutters with Weldon stem (DIN 1835-B)
- and tips with Whistle Notch stem (DIN 1835-E)

OPTIONAL:

Cod. AVK WN (\emptyset d1 = 6 - 12)

Whistle Notch Din 1835 E-Din 6535 HE

- Special screw with oscillating sphere for the tightening of tools with inclined layout 2° "AVSH WN".
- With back-up screw "RVR"

Accessori | Accessories

PST



p. 304

ASC



p. 310

AVK WN



p. 350

Ricambi | Spare parts

RVD 1835



p. 353

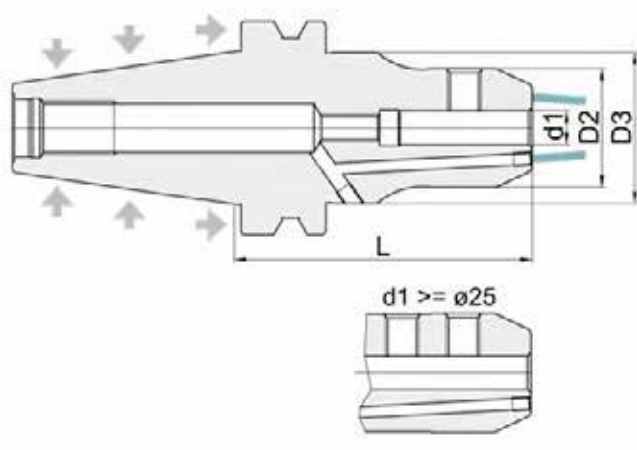

BTC 040 (JD form) - WEW Weldon

codice - code	d1	L	D2			APPLICATION
BTC.040.WEW06.060	6	60	25			DIN 6535 HBDIN 6535 HE
BTC.040.WEW08.060	8	60	28			DIN 6535 HBDIN 6535 HE
BTC.040.WEW10.065	10	65	35			DIN 6535 HBDIN 6535 HE
BTC.040.WEW12.065	12	65	42			DIN 6535 HBDIN 6535 HE
BTC.040.WEW16.070	16	70	48			DIN 6535 HB
BTC.040.WEW20.070	20	70	52			DIN 6535 HB
BTC.040.WEW25.100	25	100	65			DIN 6535 HB
BTC.040.WEW32.100	32	100	72			DIN 6535 HB

MDH

Portafrese con filetto interno, per frese con attacco filettato

Cutter-Holder with modular threaded connection

Mandrin Porte-Fraise avec attachement modulaire fileté

Fraseraufnahme mit modular-gewinde aufnahme



G 2,5
25.000 RPM
or
U < 1 gmm



HSC

PORTAFRESE

per frese con attacco filettato

- Chuck Body Fine Balanced
G 2,5 - 25.000 Rpm - Or U < 1 gmm
- Run Out 3 micron
- S = tipo **SLIM** - Adatto **PER STAMPI**
- **D3 minore** del Ø Max Fresa filettata

CUTTER-HOLDERS

with modular threaded connection

- Chuck Body Fine Balanced
G 2,5 - 25.000 Rpm - Or U < 1 gmm
- Run Out 3 micron
- S = **SLIM** type - Suitable for the **MOLD**
- **D3 < Max Ø** threaded type cutter

Accessori | Accessories

PST



p. 304

MDM



p. 54

MDM ER



p. 55

ASC



p. 310

Ricambi | Spare parts

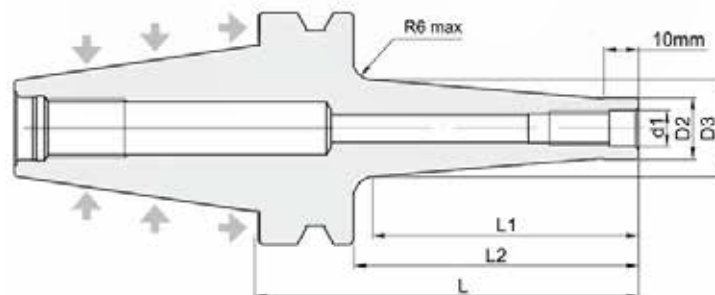

BTC 040 (JD form) - MDH

CODICE-CODE	d1	L	D2	D3		L1	L2	APPLICATION
BTC.040.MDH10.050-S	10,5-M10	83	18	19,5		50	56	SLIM
BTC.040.MDH10.070-S	10,5-M10	103	18	19,5		70	76	SLIM
BTC.040.MDH10.090-S	10,5-M10	123	18	19,5		90	96	SLIM
BTC.040.MDH12.050-S	12,5-M12	83	21	24		50	56	SLIM
BTC.040.MDH12.070-S	12,5-M12	103	21	24		70	76	SLIM
BTC.040.MDH12.090-S	12,5-M12	123	21	24		90	96	SLIM
BTC.040.MDH16.050-S	17-M16	83	29	31		50	56	SLIM
BTC.040.MDH16.070-S	17-M16	103	29	31		70	76	SLIM
BTC.040.MDH16.090-S	17-M16	123	29	31		90	96	SLIM
BTC.040.MDH16.120-S	17-M16	153	29	31		120	126	SLIM

FSW Cooling Plus Din 6357-B

Portafrese a spianare con trascinatore fisso con canali di lubrificazione

Face mill arbor with coolant bores

Porte-fraises à surfer avec conduits d'arrosage

Messerkopf- aufnahme mit Kühlmittelbohrun



G 2,5
25.000 RPM
or
U < 1 gmm

3 μm



HPC

PORTAFRESE

con canali di lubrificazione

PORTAFRESE A SPIANARE CON TRASCINATORE FISSO

- Chuck Body Fine Balanced
- G 2,5 - 25.000 Rpm - Or U < 1 gmm
- Run Out 3 micron
- Fori di refrigerazione "STANDARD"

FACE MILL ARBOR

with coolant channels

FACE MILL ARBOR WITH COOLANT CHANNELS

- Chuck Body Fine Balanced
- G 2,5 - 25.000 Rpm - Or U < 1 gmm
- Run Out 3 micron
- With "STANDARD" coolant channels

Accessori | Accessories

PST



p. 304

ASC



p. 310

Ricambi | Spare parts

RVU 5931



p. 355

RCT FM/DP



p. 355

RVU 5933



p. 355

RRS FM



p. 356

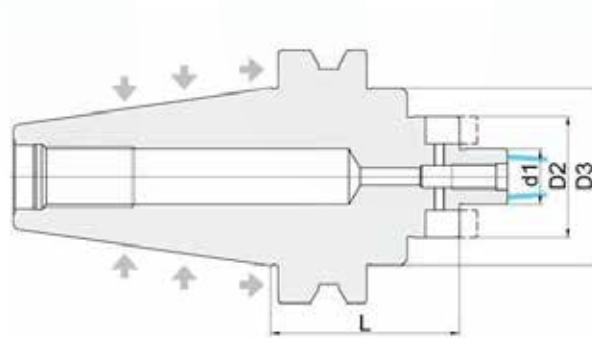

BTC 040 (JD form) - FSW

CODICE-CODE	d1	L	D2				APPLICATION
BTC.040.FSW16.050	16	50	38				
BTC.040.FSW22.050	22	50	48				
BTC.040.FSW27.050	27	50	58				
BTC.040.FSW32.050	32	50	78				



ul. Dziewosłęby 14/1, 04-403 Warszawa

Tel: +48 22 673 55 48

info@stmech.pl www.stmech.pl